

FLEX G1000DBL LEVER CONTROLLED - FLEX G1000DBR REMOTE CONTROLLED

ELECTRIC DRIVEN SWIVEL CRANE 1.000 KG CAPACITY



Our model FLEX G1000DB is a full electric powered counterbalanced mobile swivel crane with a lifting capacity up to 1 ton. One of the key features of this pick and carry crane is that there are no lateral outriggers, therefore this crane grants max mobility with suspended load. It is equipped with AGM batteries that can be recharged in areas with limited ventilation. This crane is just 1000 mm wide and thanks to its extreme maneuverability it can reach any location where the load has to be picked up, including narrow aisles and tunnels. It has an excellent steering angle that allows it to move along the narrow spaces or rotate on its axis in limited spaces. Flex G1000DB is an electric mobile lifting crane that can be used in all sectors being silent, environmentally friendly and zero-emission. In line with Health and Safety international standards (emergency buttons, warning devices, relief and check valves). It is equipped with a maximum load dynamic throttling device, which prevents the crane from loading beyond maximum range at each point of the slide by inhibiting the ascent and feed controls until the operator re-enters the load within the permitted limits. This electric mobile lifting crane can be equipped with any type of under hook accessory (vacuum lifter, bars, beans, clamps, tilters, permanent magnets and customised solutions) for unlimited applications in a large variety of industries.

Available in 2 versions:

Flex G1000DBL equipped with 2 control levers that make it possible to activate the upward/downward motion of the jib arm as well as the extension, retraction and rotation with progressive speed.

Flex G1000DBR equipped with remote control that make it possible to activate the upward/downward motion of the jib arm as well as the extension, retraction and rotation with progressive speed.

Technical data	UM	FLEX G1000DB
Weight	[kg]	1580
Max capacity	[kg]	1000
Lifting motor	[W]	800
Traction motor	[W]	1000
Tank capacity	[L]	2,5

Traction and controller			
2 AGM airtight batteries		1 battery charger	
[V]	[A]	[V]	[A]
2 x 12	2 x 120	24	12

TILLER ARM

Maximum ergonomics : the operator can firmly grip the tiller handles with both hands

Safe driving : Tiller arm safety switch disables operation in non-allowed positions

Slow/fast speed : 2-speed driving

Slow mode of 1.5 km/hr ideal for tight spaces and to safely move the load

Standard speed of 3.0 km/hr to drive the crane along long distances

Audible motion warning device : Horn with anti-noise polyester axial capacitor

Anti-crush belly button: anti-crush button with automatic reversing switch to ensure the safety of the operator in every maneuvering operation

2 butterfly controls: for forward travel and backward travel controls



CONTROLS, WARNING LIGHTS AND STANDARD FEATURES

2 position **key switch** ; **emergency button** ; **Green indicator light** showing maximum load position and the upward/downward motion and extension & retraction motion are active; **Red control light** showing maximum load capacity (when the red light is activated is not possible to lift the load and extend the jib); Indicator showing the **battery charge level**; **Schuko socket** for 220V charge ; Visual warning **LED beacon**; **24V intermittent buzzer** when the crane is moving to increase operator safety; **Storage compartment**.

ORBIT 200EL is equipped with proportional control levers with adjustable speed

- 1) controls jib upward/downward motion
- 2) controls jib extension & retraction
- 3) controls column rotation

ORBIT 200ER 200EL is equipped with remote control with proportional and adjustable speed . The remote control handle is equipped with a button , that allows you to activate the proportional control mode.

- 1) Lever that controls the jib upward/downward motion
- 2) Lever that controls the jib extension & retraction
- 3) Lever that controls the column rotation



BUILT-IN CHARGER

Pulse model with single phase 220V high frequency input voltage and 24V output voltage. Microprocessor indicator with relay for lifting block.

3 LEDs that indicate the operating status. **Remote RBC indicator** for displaying the charging phase of the battery charger.



DYNAMIC LOAD LIMITER

System for preventing overloading in each position of the extension that activates a mechanism that blocks the upward and extension motion ensuring the functionality of the crane in absolute safety and that signals when the crane returns to allowed position, re-enabling the controls.



POWER DRIVE

AC **traction motor** with recovery braking. Permanent magnet **drive wheel** in direct current 24V 700W; high frequency **MOSFET controller**.



FLEX G1000DBL / FLEX G1000DBR
CAPACITY 1000 KG
LOADING CHART WITH DOUBLE TELESCOPIC BOOM

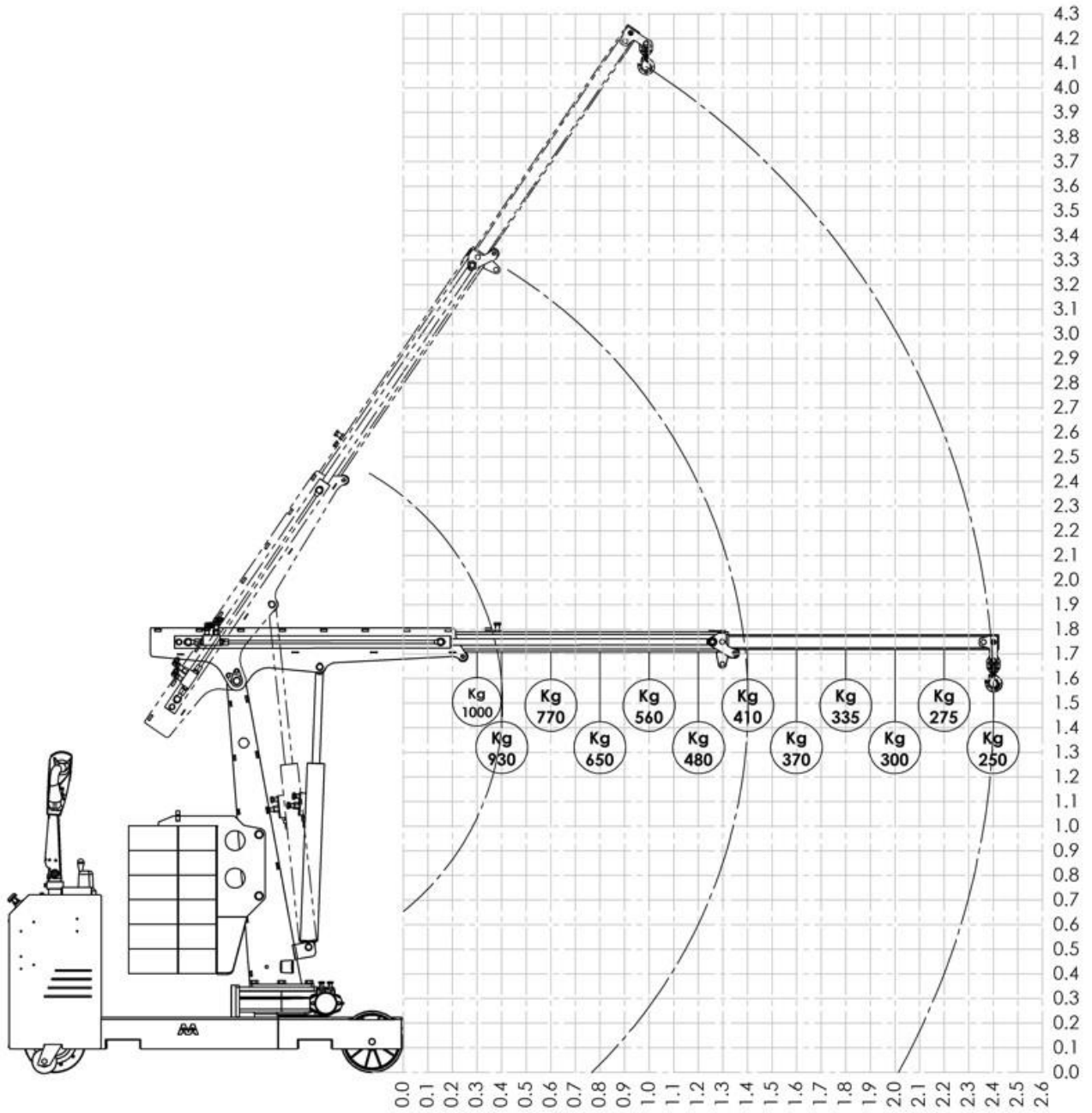

FLEX G1000DBL / FLEX G1000DBR

TECHNICAL DRAWINGS AND DIMENSIONS

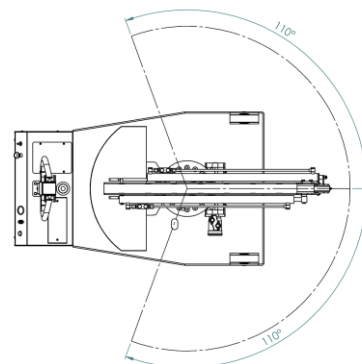
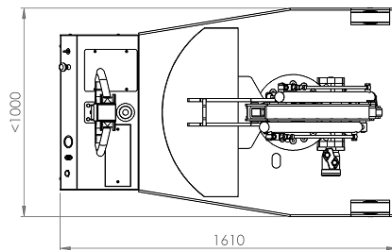
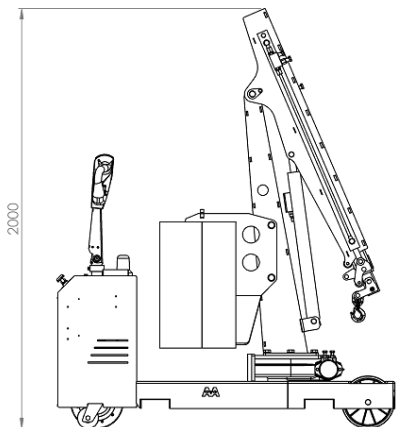
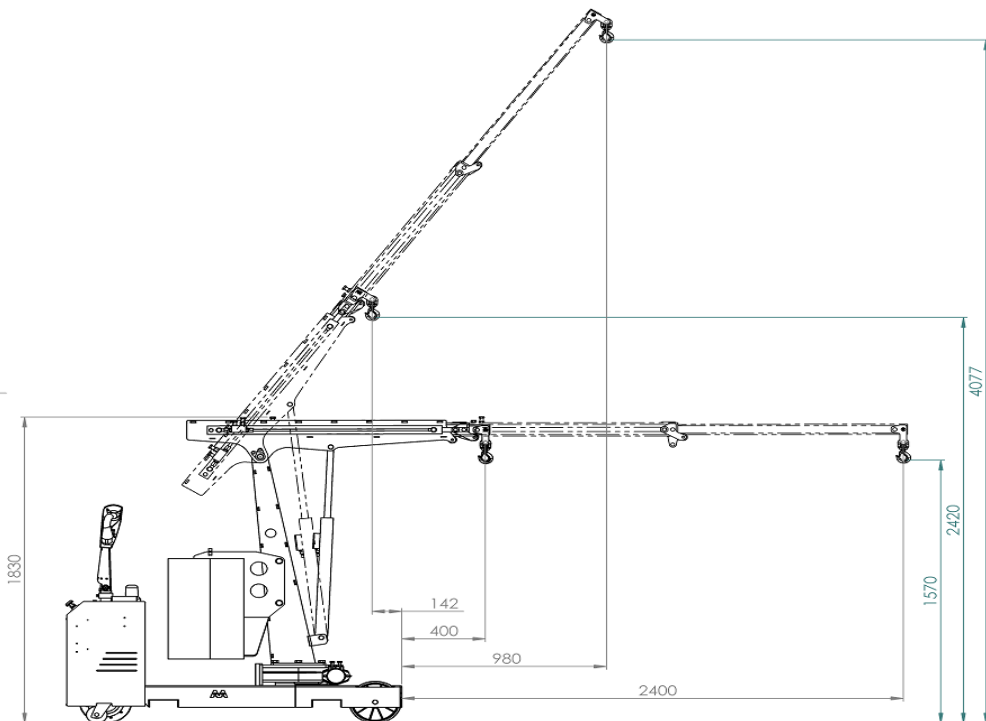

FLEX G1000DBL / FLEX G1000DBR

WIDTH WITH ARM ROTATED AT 90°

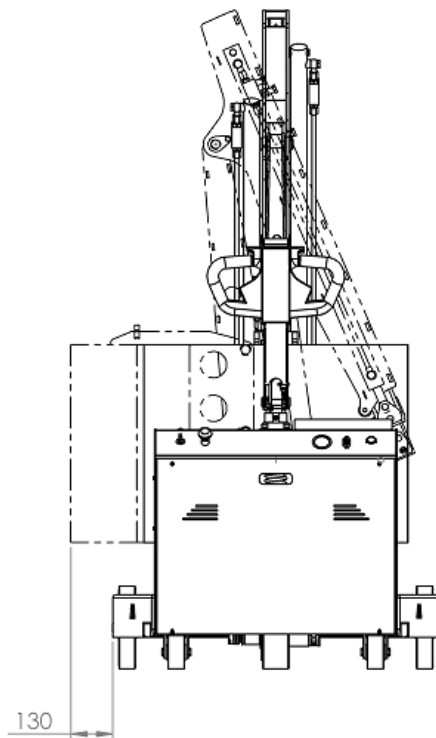
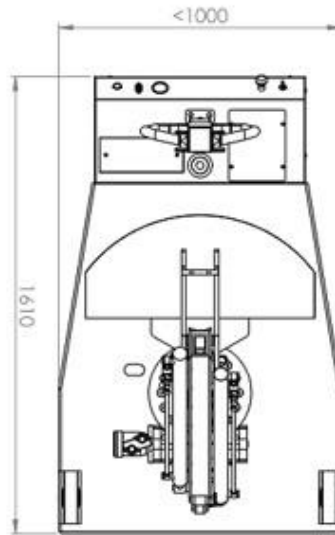

WITH STANDARD BALLAST:
 WHEN THE ARM IS ROTATED AT 90°
 THE BALLAST **EXCEEDS** THE CRANE
 WIDTH BY 130 MM

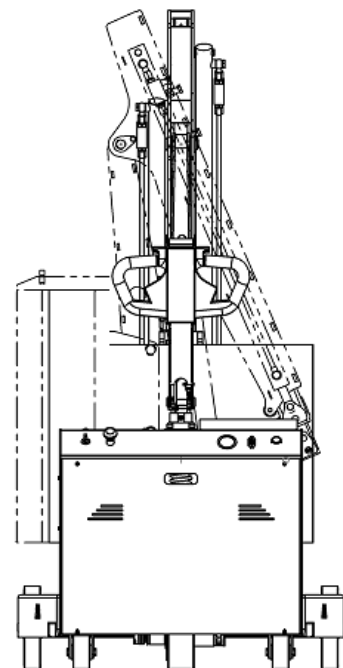

**UPGRADE TO COMPACT BALLAST
 (OPTIONAL)**
 WHEN THE ARM IS ROTATED AT 90° THE
 BALLAST **DOESN'T EXCEED** THE CRANE
 WIDTH OF 1.000 MM