

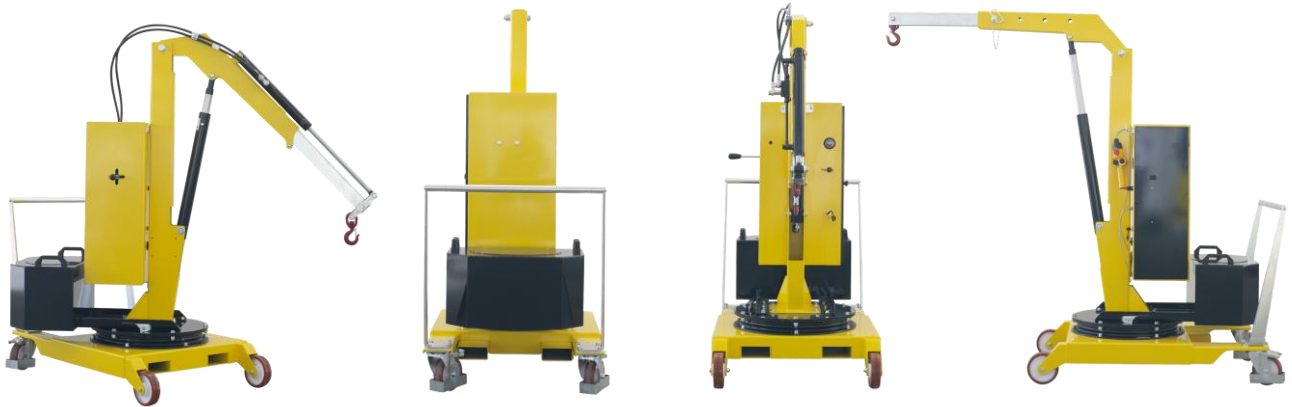

Flexibility, innovation  
and safety  
for your work

**COUNTERBALANCED 360° SWIVEL CRANES**



A complete range of counterbalanced 360° swivel cranes with manual traction. Hydraulic lever controlled or electric controlled. They represent the most cost-effective and flexible solution for lifting and transporting loads in several applications such as machining centers and machine tools, delivery to assembly lines, assembly operations, goods handling. Thanks to their compact dimensions they are easily maneuverable even at full load and can be moved effortlessly in confined spaces. All components are made in Italy to ensure the highest construction quality and the absence of defects.

The hydraulic system is equipped with a lock valve that prevents the load from falling in case of accidental breakage of the pipes and a rough valve that prevents overloading of the crane.

They are equipped with 2 high-capacity pivoting wheels with bumper mounts and parking brakes and with 2 fixed front wheels with bearings. The frame is made of painted steel and is equipped at the base with 2 useful forklift supports (to lift and transport the crane in complete safety on long distances). The sturdy push handle can be disassembled. There are also 2 handles to easily rotate the ballast. Swivel hook type. Rotating jib arm with 8 locking positions.

**CERTIFICATION AND COMPLIANCE WITH REGULATIONS FOR THE PROTECTION AND SAFETY IN THE WORKPLACE**

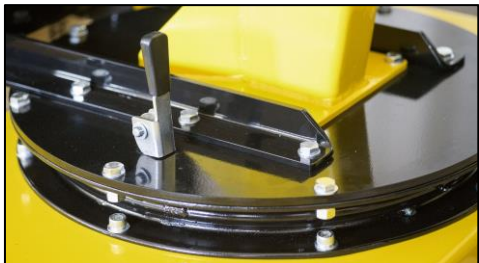

# 01B5SE\_1000

## CAPACITY 500 KG

**COUNTERBALANCED SWIVEL CRANE , POWERED LIFT /LOWER & POWERED EXTEND/RETRACT JIB ARM WITH PROGRESSIVE SPEED**



Technical data	UM	01B5SE_1000
Weight	[kg]	680
Max capacity	[kg]	500
Max pressure	[bar]	140
Tank capacity	[Liters]	2,5
Cylinder stroke	[mm]	470

01B5SE: CAPACITY AND DIMENSIONS WITH STANDARD JIB ARM	
Length	Capacity
[mm]	[kg]
from 410 to 1410	from 500 to 200

CAPACITY WITH OPTIONAL EXTENDED JIB ARM	
Length	Capacity
[mm]	[kg]
from 1410 to 1910	FIX CAPACITY 100

1 battery	[V]	12
	[A]	80
Battery charger	[V]	220
	[A]	12

Model 01B5SE\_1000 is equipped with an electric controlled jib arm. It is equipped with a 4 way fine control lever controls for :

- Lifting the jib arm
- Lowering the jib arm
- Extending the jib arm
- Retracting the jib arm

All movements (arm and extension) are electric controlled, progressive and adjustable by the operator with extreme precision. Controlled descent system with the engine off.

**Model 01B5SE\_1000 is the most popular model for awkward placements from the ground onto 3D machines, lathes, over perimeter protections, narrow openings, etc., thanks to its 360° pivoting and in all those applications where there is no space to move the load with a forklift or other large sizes lifting equipment.**

Detail of the 4 way fine control lever



**01B5SE\_1000**  
**TECHNICAL DRAWINGS & DIMENSIONS**  
*The right crane for endless applications  
and the best performance*

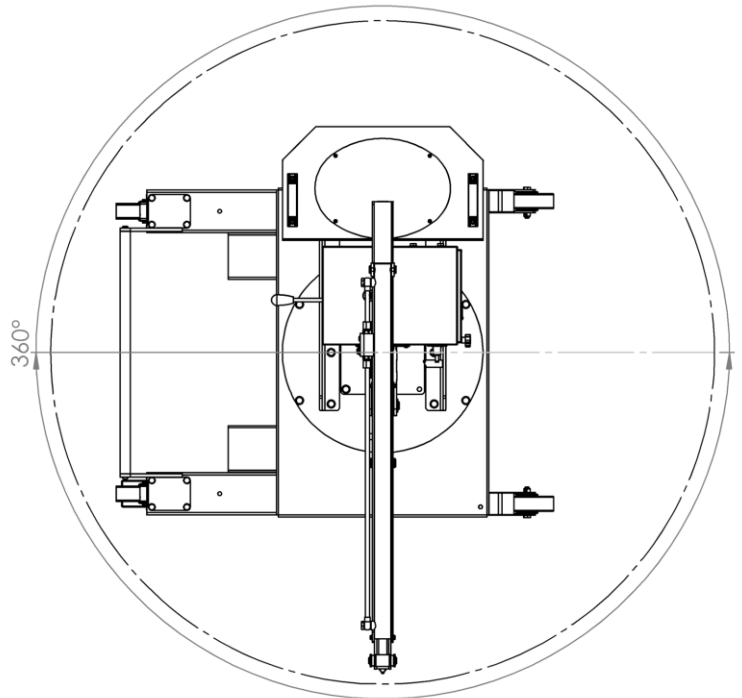
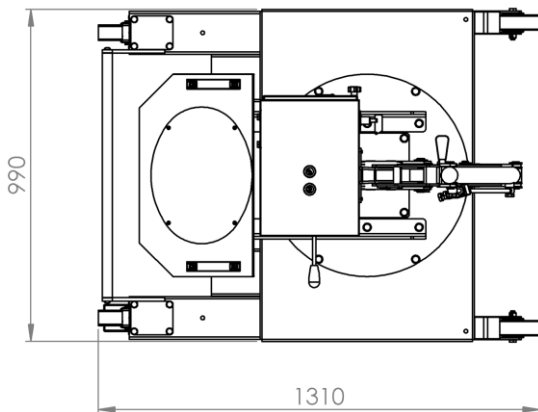
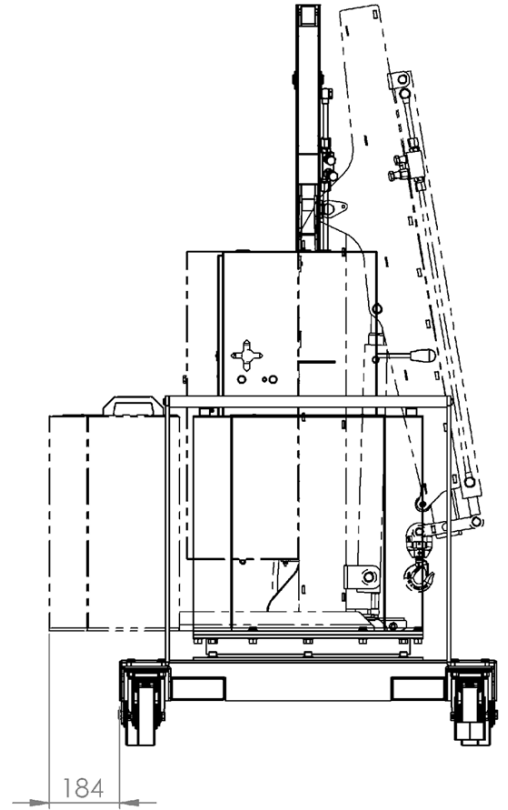
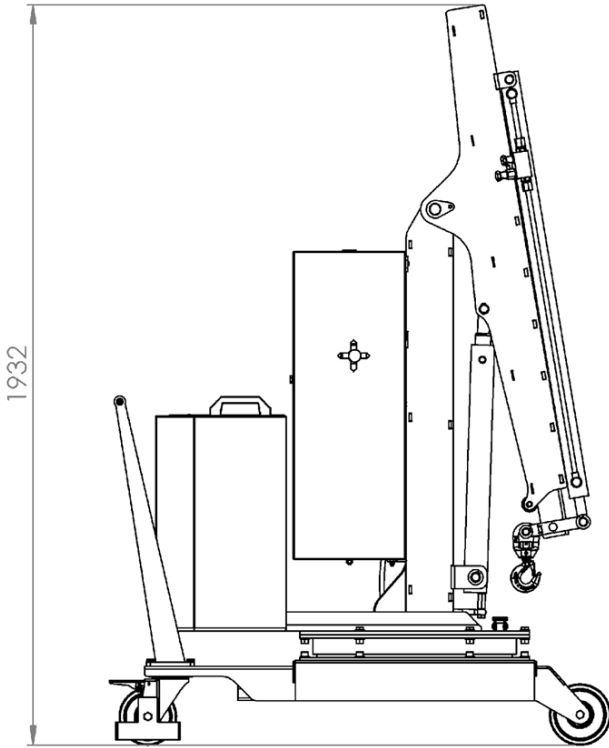

**01B5SE\_1000**  
**CAPACITY 500 KG**  
**LOADING CHART**

